

RESEARCH ARTICLE

Influence of Different Ceramic Systems on the Polymerization of Dual-cured Resin Cement evaluated Immediately and after 24 Hours: An *in vitro* Study

¹Nikhil V Jain, ²Ramandeep Dugal, ³Pallavi Madanshetty, ⁴Gaurav R Poplai, ⁵Affaf A Gharatkar, ⁶Purva H Shinde

ABSTRACT

Background: To check the influence of different All-ceramic systems on the polymerization of a dual-cured resin cement, evaluated immediately and 24 hours after curing cycle.

Materials and Methods: A total of 80 resin cement disc specimens (n = 20) were fabricated by polymerization through lithium disilicate disks (group B), leucite-reinforced disks (group C), zirconia disks (group D) and without an intervening ceramic disk (group A). Each group further consisted of two sub-groups (n = 10), t 30 and t 60 according to two different exposure times of 30 seconds and 60 seconds, respectively. Each of the 80 resin disk specimens was evaluated for microhardness (VHN) immediately and after 24 hours, giving us a total of 160 readings. One way analysis of variance (ANOVA) test was used for multiple group comparisons followed by Tukey's post-hoc for group-wise comparisons.

Results: Direct activation (group A) of the resin cement showed statistically significant higher mean microhardness values as compared to the experimental groups (groups B, C and D), both immediately and after 24 hours. The mean microhardness for immediate post-activation was always inferior to the 24 hours post-activation test for both direct activation and through different ceramics. For immediate testing time, of both the 30 seconds and 60 seconds curing cycle, there was a significant increase in the microhardness of the resin cement disks cured for 60 seconds through the different ceramics (groups B, C and D) and direct light activation (group A). For the 24 hours testing time, of both the 30 seconds and 60 seconds curing cycle, there was a significant increase in the microhardness of the resin cement disks cured for 60 seconds through the different ceramics except for the direct light-activation group.

Conclusion: Ceramic composition affected the polymerization of dual-cured resin cements. Doubling the light irradiation time significantly increased mean microhardness value. Greater degree of conversion leading to an increase in hardness was observed when the resin cement disks were evaluated after 24 hours.

Keywords: Ceramic, Light-emitting diode, Microhardness, Polymerization, Resin cement.

How to cite this article: Jain NV, Dugal R, Madanshetty P, Poplai GR, Gharatkar AA, Shinde PH. Influence of Different Ceramic Systems on the Polymerization of Dual-cured Resin Cement evaluated Immediately and after 24 Hours. An *in vitro* Study. *Int J Prosthodont Restor Dent* 2015;5(1):1-9

Source of support: Nil

Conflict of interest: None

INTRODUCTION

Over the past decade an increasingly high demand for esthetically pleasing restorations has driven the development of different all-ceramic systems. Glass-based systems with fillers like lithium disilicate and leucite reinforced ceramics have a potential application in anterior restorations due to excellent esthetics, chemical snertness and a variety of unique physical properties, such as strength, machinability, transparency and thermal shock resistance.¹ Partially stabilized zirconia due to its unsurpassed mechanical properties is the strongest and toughest ceramic material² and hence, has the potential to be used as a reliable, multiunit all-ceramic restorations for high-stress areas, such as posterior region of the mouth.³

Resin-based composite bonding and luting technology is considered an inherent part of the state of the art all-ceramic restorations.⁴ Their ability to adhere to multiple substrates, high strength, insolubility in oral environment and shade matching potential have made resin cements the adhesives of choice.⁵

All-ceramic restorations do not have the underlying metal support unlike porcelain-fused-to-metal (PFM) restorations. Therefore, the underlying cement/tooth combination should provide the support for these brittle materials during loading.⁴ Within the literature,⁶⁻⁸ a number of mechanisms have been proposed to explain the apparent strengthening of all-ceramic restorations

^{1,2,6}Maxillofacial Prosthodontist and Oral Implantologist

³General Dentist, ^{4,5}Endodontist

^{1-3,6}Department of Maxillofacial Prosthodontics and Oral Implantology, MA Rangoonwala College of Dental Sciences and Research Centre, Pune, Maharashtra, India

⁴Department of Conservative Dentistry and Endodontics, Terna Dental College, Navi Mumbai, Maharashtra, India

⁵Department of Conservative Dentistry and Endodontics, MA Rangoonwala College of Dental Sciences and Research Centre, Pune, Maharashtra, India

Corresponding Author: Nikhil V Jain, Maxillofacial Prosthodontist and Oral Implantologist, Department of Maxillofacial Prosthodontics and Oral Implantology, MA Rangoonwala College of Dental Sciences and Research Center, Pune, Maharashtra, India, Phone: +91 99-75-507714, e-mail: drnikhiljain@outlook.com

cemented with resin luting agents. Marquis has reported a crack healing mechanism, wherein the resin cement partially or fully infiltrates the surface defect, thereby reducing the effective crack length and, hence, the stress intensity at the crack tip.⁹ This leads to an increase in the fracture toughness of all-ceramic restorations. By virtue of a strong bond and increase in ceramic fracture toughness, resin-based cements play an important role in the stability, clinical performance and longevity of ceramic restorations.

Dual-cure resin luting agents were developed in an attempt to combine the desirable properties of self-cure and light-cure resin cements. The chemical polymerizing component is expected to ensure complete polymerization at the bottom of deep cavities, whereas photo-activation allows immediate finishing after exposure to the curing light.¹⁰

Although these materials undergo a dual polymerization mode, many studies have shown that the self-curing mechanism of some dual-cured cements is inadequate.^{11,12} and a sufficient amount of light is needed to start the process of polymerization.¹³ If a dual cured resin material does not receive sufficient number of photons at the correct wavelength, the amount of polymerization and degree of conversion (DC) will be inadequate, compromising the retention of the prosthesis.¹⁴

The amount of light passing through ceramics from different manufacturers varies depending upon their crystal content and composition.¹⁵ More light is expected to be attenuated by crystalline ceramics as they are opaque.¹⁶

The exposure times recommended by the manufacturer for photocuring the dual cure roughly correspond to the time needed to achieve maximum hardness of resin cements directly exposed to light.¹⁷ But the compensation for the attenuation of light by different ceramic materials is not considered. Strydom¹⁸ has indicated that irradiation times used by dentists for light-polymerizing cements are too short. Longer polymerization times are necessary to compensate for the decrease in light intensity incident upon the resin adhesive due to both the overlying ceramic material and light source factors in order to achieve an adequate degree of polymerization.

Therefore, this study was undertaken to check if a higher DC of resin cement could be obtained by increas-

ing the exposure time than that recommended by the manufacturer in order to compensate for the attenuated light due to the overlying all-ceramic restoration.¹⁷

MATERIALS AND METHODS

Fabrication of Ceramic Specimens (Table 1)

Leucite reinforced (IPs Empress), lithium disilicate (IPs Emax) and zirconia (Cercon) disks of 8 mm in diameter and final thickness of 1.2 mm as measured on a digital vernier caliper were obtained.

IPS Empress esthetic ingot for staining technique (shade ETC 1) was pressed and stain fired with IPS Empress Universal Stains (A3) and glazed to obtain the leucite reinforced disk.

An ingot of IPS e.max of shade MO 1 was pressed and a core thickness of 0.7 mm thickness was obtained. Porcelain Emax Ceram shade dentin A3 was applied and fired to obtain the lithium disilicate disk. The disk was ground to obtain a total thickness of 1.2 mm and was subjected to finishing and glaze firing (Fig. 1).

To fabricate the zirconia disc, a wax pattern which was 0.4 mm in thickness and 8 mm in diameter was obtained. Cercon brain unit was used for scanning the wax pattern. Milling of a base blank of pre-sintered zirconia followed by sintering to a fully dense structure was done. IPS e.max Ceram, shade dentin A3 was layered and fired, the disc was then finished and glazed to obtain a final disc thickness of 1.2 mm.



Fig. 1: Lithium disilicate disk after layering showing thickness of 1.2 mm

Table 1: Materials, brand names, manufacturers, composition and batch number of different ceramics used

Materials	Brand name	Manufacturer	Composition	Batch number
Leucite ceramic	IPS empress	Ivoclar-vivadent, schaan, liechtenstein	SiO ₂ , Al ₂ O ₃ , K ₂ O, Na ₂ O, CeO ₂ , B ₂ O, CaO, BaO, TiO ₂	M34776
Lithium disilicate ceramic	IPS e.max	Ivoclar-vivadent, schaan, liechtenstein	SiO ₂ , Al ₂ O ₃ , La ₂ O ₃ , MgO, ZnO, K ₂ O, Li ₂ O, P ₂ O ₅	N18623
Zirconia ceramic	Cercon	DeguDent, Hanau, Germany	ZrO ₂ , Y ₂ O ₃ , HfO ₃ , SiO ₂ , Al ₂ O ₃	20018669



Resin Cement (Variolink N)

Variolink N resin luting agent, transparent shade was used. The monomer matrix of Variolink N is composed of Bis-GMA, urethane dimethacrylate, and triethylene glycol dimethacrylate. The inorganic fillers are barium glass, ytterbium trifluoride, Ba-Al-fluorosilicate glass, and spheroid mixed oxide. Additional contents are catalysts, stabilizers and pigments. The particle size is 0.04 to 3.0 μm . The mean particle size is 0.7 μm . It is provided with two paste systems with the base paste containing camphoroquinone, both aliphatic amine and aromatic tertiary amine, and the catalyst paste containing benzoyl peroxide.^{27,41} The recommended light curing duration is 30 seconds.

Light Curing Unit (Bluephase)

A light emitting diode (Bluephase, Ivoclar-Vivadent, Schaan, Liechtenstein) with an irradiance of 643 mW/cm^2 (Fig. 2) and a diameter of 9 mm at the curing tip was used.

Fabrication of Elastomeric Mold

A metal cylinder (5 mm in diameter and 1 mm thick) was secured onto a glass slab. An impression of this metal cylinder was made in polyvinyl siloxane impression material creating an elastomeric mold with a centered aperture of the same dimension as the metal cylinder. The purpose of using a dark orange colored impression material was to impede light transmittance through it, allowing the luting agent to be exposed to the polymerization light solely from above.

Methodology

The base and a low viscosity catalyst paste of the Variolink N resin cement were mixed in a 1:1 ratio according to manufacturer's instructions and inserted into the

cylindrical elastomeric mold. A transparent Mylar's strip was then placed over the filled orifice. The resin cement was activated by a light emitting diode with an irradiance of 643 mW/cm^2 . The light intensity was measured with a hand-held radiometer. Four experimental groups ($n = 20$) were formed, which together consisted of 80 resin cement disk ($N = 80$) specimens (Flow Chart 1).

- *Group A*: Control group (without an intervening ceramic disk).
- *Group B*: Resin cement disks cured through lithium disilicate disk.
- *Group C*: Resin cement disks cured through leucite-reinforced disk.

Group D: Resin cement disks cured through zirconia.

The control group specimens were obtained by direct activation, i.e. without interposing any ceramic disk in-between the resin cement and the light source. The wand tip of light curing unit was held in contact with the Mylar's strip (Fig. 3).

To obtain the Experimental group (groups B, C, D) specimens, one of the three ceramic disks was placed on the strip. During photo-activation, the wand tip of light curing unit was held in contact with the ceramic disc.

Each group further consisted of two subgroups ($n = 10$), t30 and t60 according to two different exposure times of 30 seconds and 60 seconds respectively.

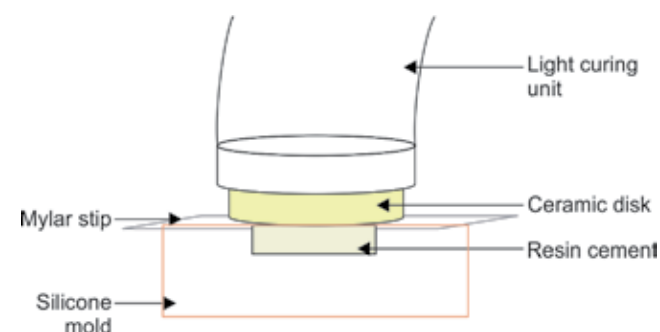

Fig. 3: Schematic diagram of the experimental set-up to irradiate specimens through machinable ceramic



Fig. 2: Radiometer showing the light intensity

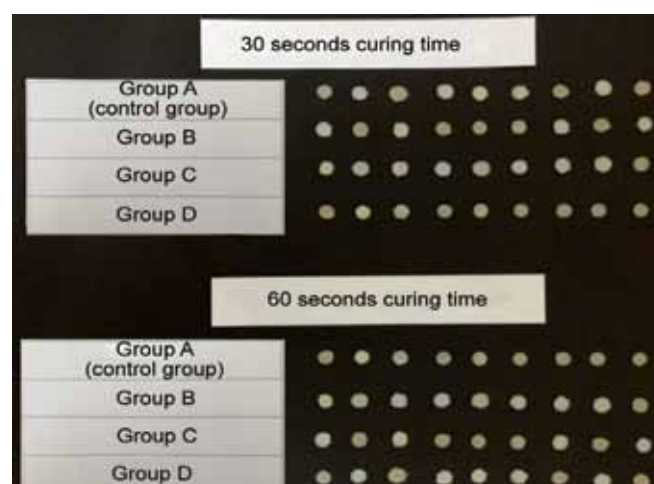
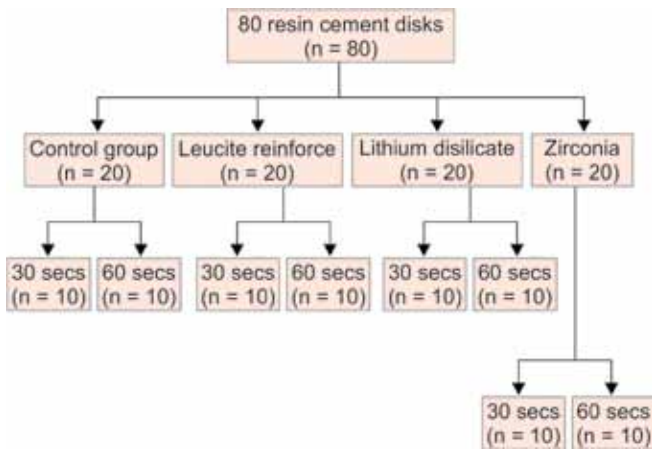

Fig. 4: Resin cement disk specimens

Flow chart 1: Experimental groups



Each of the 80 resin disk specimens (Fig. 4) was evaluated for microhardness (VHN) immediately (within 10 minutes) and after 24 hours, giving us a total of 160 readings. In the 24-hour post-cure time, the specimens were stored in lightproof containers at 37°C for 24 hours and were then evaluated by microhardness testing for degree of polymerization.

Surface Hardness Measurement

Degree of conversion (DC) of resin cement specimens was expressed in terms of Vickers hardness number (VHN), using a universal indenter tester with a Vickers hardness indenter.

Vickers hardness number is a measure of the hardness of the material. It is calculated from the size of an impression produced under a specified load for a specified length of time by a pyramid-shaped diamond indenter.

To perform the Vickers test, the resin cement disk was placed on an anvil that had a screw threaded base. The anvil was turned and raised by the screw threads until it was close to the point of the indenter (Fig. 5). The surface of the resin cement disk facing the light source was subjected to a static load of 50 gm for 15 seconds by



Fig. 5: Pyramid-shaped Vickers hardness indenter

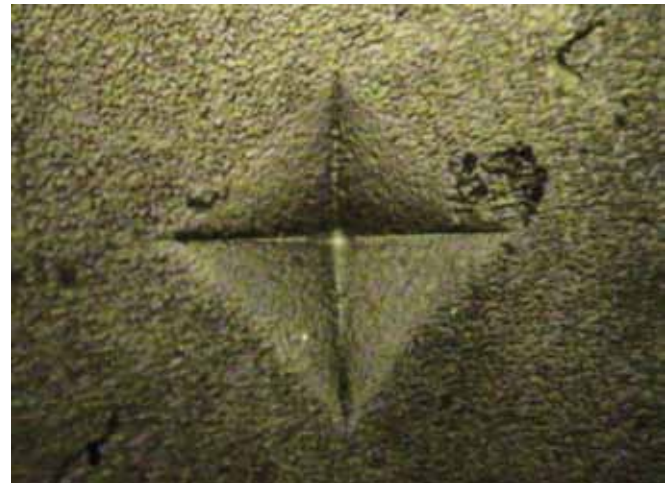

Fig. 6: Microscopic image of indentation at 40x magnification

means of a diamond indenter. The load was released and the anvil with the specimen was lowered. The applying of load and removing it was automatically controlled.

The indenter employed in the Vickers test was a square-based pyramid whose opposite sides met the apex at an angle of 136°. A calibrated microscope was used to measure the square indentation to a tolerance of $\pm 1/1000$ of a millimeter. The two diagonals of the indentation left in the surface of the resin cement disk after removal of the load were measured using a calibrated microscope at 40x magnification (Fig. 6) and their average calculated. The area of the sloping surface of the indentation was calculated. The Vickers hardness is the quotient obtained by dividing the load by the square mm area of the indentation.

The Vickers hardness was calculated using the formula, $H = P/A$, where H is Vickers hardness number, P is load and A is area.

STATISTICAL ANALYSIS

The data were continuous type hence, parametric tests were used for analysis. Mean and standard deviation (SD) were calculated. Paired sample t-test was used for comparison and one way analysis of variance (ANOVA) test was used for multiple group comparisons followed by Tukey's post hoc for group wise comparisons. Statistical analysis was done with SPSS (version 17) USA.

RESULTS

The results of the microhardness testing are shown in Tables 2 and 3 and Graphs 1 and 2. Tables 2 and 3 indicate the mean and standard deviation of VHN for each group after 30 seconds and 60 seconds of curing time respectively. The ceramic composition and also the post-activation testing time affected the microhardness of the resin cement. Direct activation (group A) of the resin cement showed statistically significant higher mean



Table 2: Mean microhardness (VHN) values evaluated immediately and 24 hours after polymerization for 30 seconds curing cycle

Study groups	Microhardness [Mean (SD)] in VHN	
	Immediately	24 hours
Control group	29.13 (1.3813)	53.45 (1.9011)
Lithium disilicate	23.54 (1.4094)	29.18 (1.3479)
Leucite reinforced	25.19 (0.8858)	31.33 (0.8965)
Zirconia	16.675 (0.4094)	26.9 (0.5708)
ANOVA F-value	216.733	920.953
p-value	0.00, S	0.00, S
Tukey's post-hoc text for pair-wise comparison	Significant difference between all the four groups immediately after curing	Significant difference between all the four groups 24 hours after curing

S: Significant

Table 3: Mean microhardness (VHN) values evaluated immediately and 24 hours after polymerization for 60 seconds curing cycle

Study groups	Microhardness [Mean (SD)] in VHN	
	Immediately	24 hours
Control group	39.54 (0.932)	56.90 (0.668)
Lithium disilicate	29.44 (0.619)	38.12 (0.671)
Leucite reinforced	32.53 (0.590)	42.37 (0.739)
Zirconia	21.42 (0.517)	35.11 (0.597)
ANOVA F-value	1207.036	2067.223
p-value	0.000, S	0.000, S
Tukey's post-hoc text for pairwise comparison	Significant difference between all the four groups immediately after curing	Significant difference between all the four groups 24 hours after curing

S: Significant

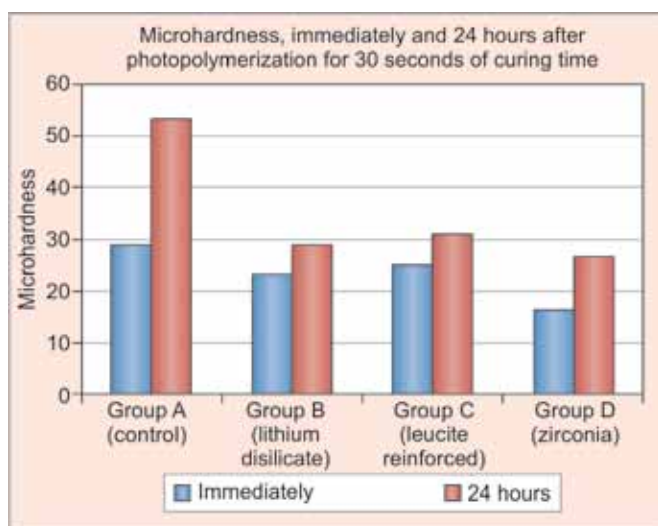
**Graph 1:** Microhardness values (VHN) of groups A, B, C and D for subgroup t_{30} , immediately and 24 hours after photopolymerization

microhardness values as compared to the experimental groups (groups B, C and D), both immediately and after 24 hours. The mean microhardness for immediate post-activation was always inferior to the 24 hours post-activation test for both direct activation and through different ceramics.

For immediate testing time, of both the 30 seconds and 60 seconds curing cycle (Table 4 and Graph 3), there was a significant increase in the microhardness of the resin cements discs cured for 60 seconds through the different ceramics (groups B, C and D) and direct light activation (groups A). Empress 2 was statistically inferior

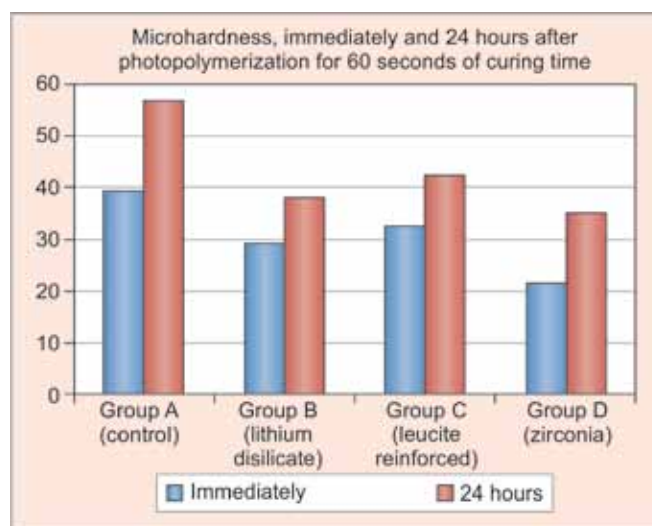
**Graph 2:** Microhardness values (VHN) of groups A, B, C and D for subgroup t_{60} , immediately and 24 hours after photopolymerization

to the direct group; however, it was superior to E-max and Cercon groups with the latter giving the least values.

For the 24-hour testing time, of both the 30 and 60 seconds curing cycle (Table 5 and Graph 4), there was a significant increase in the microhardness of the resin cement discs cured for 60 seconds through the different ceramics except for the direct light-activation group. The microhardness values were in the descending order of control group (group A) followed by Empress 2 (group C), then E-max (group B) and Cercon (group D).

There was a significant increase in the polymerization of all the groups including the control group when tested

Table 4: Effect of different exposure times on microhardness (VHN) of dual-cured resin cement immediately after curing

Study groups	Curing time		Independent sample test t-value	p-value
	30 seconds	60 seconds		
Control groups	29.13 (1.3813)	39.54 (0.932)	- 19.754	0.000, S
Lithium disilicate	23.54 (1.4094)	29.44 (0.619)	- 12.119	0.000, S
Leucite reinforced	25.19 (0.8858)	32.53 (0.590)	- 21.800	0.000, S
Zirconia	16.27 (0.4094)	21.42 (0.517)	- 21.950	0.000, S

S: Significant

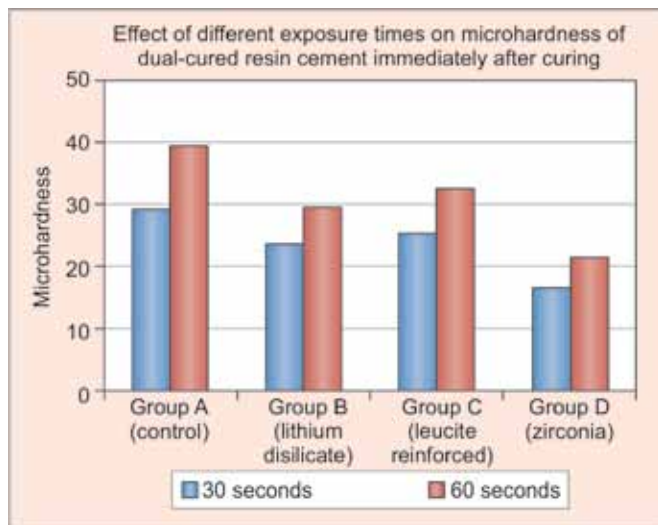
**Graph 3:** Microhardness values (VHN) of groups A, B, C and D for subgroup t_{30} and t_{60} , immediately after photopolymerization

immediately and after 24 hours for the 60 seconds curing cycle and for the 24-hour postactivation evaluation for both the 30 and 60 seconds curing cycle.

DISCUSSION

In the present study, leucite-reinforced, lithium disilicate and zirconia-based ceramics were selected. The glass ceramic disks were heat pressed and zirconia disk was fabricated using CAD/CAM technique. The choice of ceramic systems and their fabrication technique used in this study was influenced by the recent trends (Table 1).

The degree of conversion of the resin matrix has a direct influence on the mechanical properties of the resinous materials.¹⁹ Degree of conversion is the percentage of double bonds that have been converted to single bonds to form the cross-linked polymeric resin. Several studies have demonstrated that the degree of monomer conversion determines the surface hardness and wear resistance of the resin materials.^{10,20}

Various direct and indirect methods are applied to evaluate the DC of resin cements. Although FTIR^{19,21} or laser Raman spectroscopy²² are the most sensitive types of direct methods, they, however, are very expensive and time consuming.²³ The various common types of indirect methods are depth of cure¹⁵ and microhardness testing.^{16,24} These indirect methods are not only economic

but were easy to perform and exhibited differences between different exposure situations.¹⁰ In a study conducted by Rueggeberg et al,^{25,26} it was observed that surface hardness measurements showed results similar to FTIR spectroscopy. Therefore, in the present study, indentation testing (VHN) was used to check the microhardness of the dual-cured resin cement.

Albeit, the resin cement is directly cured, it shows 55 to 75% of DC. But when cured indirectly through the ceramic prosthesis, the composition, opacity, thickness and shade of the ceramic will attenuate the intensity of light^{27,28} and reduce the number of photons that reach the resin cement. The corollary is a low DC% leading to inferior physicommechanical properties and consequently, the prognosis of the indirect restorations could suffer.

There is a wide variation in the composition and crystal content of ceramics from different manufacturers, which may impact the quantity of photons that passes through them for activation of the resin cement.¹⁵ Hence, in this study, frequently used ceramic systems of different compositions and crystallinity (Table 1) were tested and a comparison has been made between direct activation and indirect activation of resin cement.

To provide a satisfactory polymerization where curing light is attenuated by the ceramic restoration, the manufacturers must increase the concentration of tertiary amine. This, however, will have the undesirable effect of making the materials less color stable. Further work is necessary to develop the appropriate balance between rate and efficiency of cure, and color stability. Strydom¹⁸ has indicated that irradiation times used by dentists for light-polymerizing cements are too short. Longer polymerization times are necessary to offset decreases in light intensity incident upon the resin adhesive due to both the overlying ceramic material and light source factors in order to achieve an adequate DC. Therefore, in this study, it has been tried to increase the efficiency of cure by increasing the light exposure time from manufacturer's recommended 30 seconds to 60 seconds in order to elevate the quantity of photons that reach the cement and to improve the DC.

The results of the current study showed lower hardness values for immediate and 24 hours testing time after 30 seconds of indirect light exposure (Table 2 and

Graph 1) through the ceramic disks as compared to the 60 seconds curing cycle (Table 3 and Graph 2). This depicts deficient polymerization of resin cement after 30 seconds curing time, which could negatively affect its physical and mechanical properties. Since it has been proven that even well polymerized resin cements can release residual monomers, it could be assumed that poorly polymerized resin cements would elute more substances from them. These substances can lead to the irritation of pulp and soft tissues, stimulate proliferation of bacteria and also cause allergic reactions. This indicates that the curing protocol has a critical effect on the hardness and is a major clinical factor influencing the clinical performance of resin-based cement.²⁹ Therefore, it could be concluded that the manufacturer's recommended 30 seconds curing protocol may not be enough to achieve satisfactory hardness and DC of resin cement.

In a clinical situation, it is important to know the immediate hardness after the initial cure of resin cement. This is critical for the initial management of the restoration, such as finishing and occlusal adjustments. Therefore, this study has evaluated initial and final hardness by measuring VHN immediately and after 24 hours.

In the present study, the immediate testing time (Table 4 and Graph 3) showed lower hardness values than the 24 hours testing time (Table 5 and Graph 4) for

both 30 and 60 seconds curing times. These results are in accordance with a study conducted by Valentino et al in 2010.³⁰ With this, one can be suspicious of the prosthesis being unstable immediately after cementation and could be dislocated by the chewing process. Thus during cementation procedure, it is recommended to follow a clinical protocol that includes additional time to allow for adequate polymerization. Moreover, the patients should be advised to avoid biting on hard foodstuff for at least the next 24 hours.³⁰

The hardness obtained by the resin cement when used under the ceramic discs was less than that of the controls that were directly exposed to light for both 30 and 60 seconds testing times, immediately and after 24 hours (Table 2, Graph 1 and Table 3, Graph 2). These findings confirm that indirect activation through the ceramic discs decrease the amount of light reaching the luting material, which needs to be compensated for, by increasing the curing cycle timings.

For the 24 hours testing time, of both the 30 seconds and 60 seconds curing cycle (Table 5, Graph 4), there was a significant increase in the microhardness of the resin cement discs cured for 60 seconds through the different ceramics except for the direct light-activation group. The control group did not show statistically significant difference in the 24 hours testing time between 30 and 60 seconds curing cycle (Graph 5). This justifies the

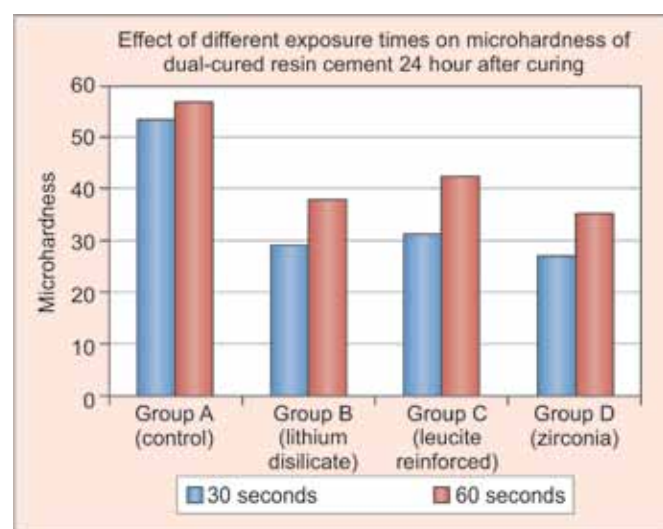

Graph 4: Microhardness values (VHN) of groups A, B, C and D for subgroup t_{30} and t_{60} , 24 hours after photopolymerization

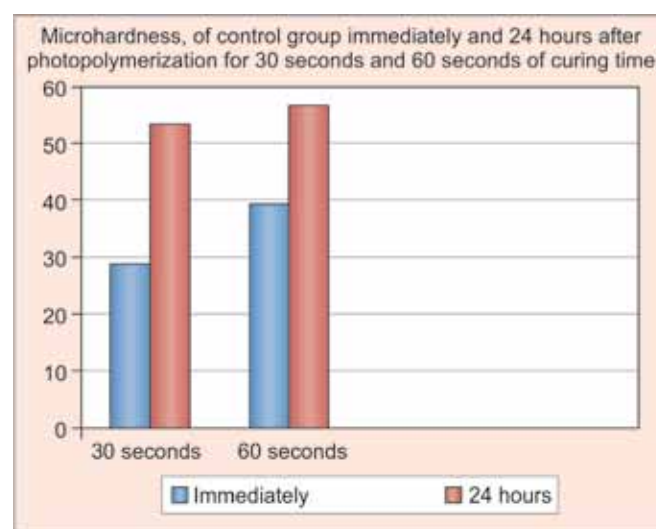

Graph 5: Microhardness values (VHN) of group A, for subgroup t_{30} and t_{60} , immediately and 24 hours after photopolymerization

Table 5: Effect of different exposure times on microhardness (VHN) of dual-cured resin cement 24 hours after curing

Study groups	Curing time		Independent sample t-test t-value	p-value
	30 seconds	60 Seconds		
Control groups	53.45 (1.9011)	56.90 (0.668)	- 5.414	0.000, S
Lithium disilicate	29.18 (1.3479)	38.12 (0.671)	- 18.772	0.000, S
Leucite reinforced	31.33 (0.8965)	42.37 (0.739)	- 30.034	0.000, S
Zirconia	26.9 (0.5708)	35.11 (0.597)	- 31.428	0.000, S

S: Significant

previous studies which have claimed that when resin based cements are polymerized in a dual mode, the faster reaction promoted by the light activation hinders the chemical component of polymerization.

Meng et al³¹ (2008) showed that even under irradiation by light of low intensity, dual-cure resin cements still had a large number of free radicals, mostly from the trapped chemical catalysts in the hardening resin matrix, which did not increase the overall DC% of materials.

Considering findings of Meng et al³¹ (2008) and the above discussion, it is fair to speculate that the chemical component of the resin cement contributed sparsely to the overall polymerization after dual activation through the different ceramic disks. Hence, a significant chemically induced continuation of the polymerization process after light initiation is difficult to achieve. Therefore, the duration of inhibition and the level of initial conversion caused by the light exposure are highly influential factors upon the final cure of a dual-cured resin.²⁶

Overall, the hardness value for indirect activation for both curing protocols were less compared to control group which could be explained by the deficiency of chemical cure component of Variolink N cement used in this study. This finding emphasizes on the fact that material choice has to be optimized taking into account the curing characteristics of the cement.

The results of the current study report different VHN values of resin cement when cured under different ceramics. This suggests that the type (composition) of ceramic influences the degree of polymerization. In general, the results show that the VHN for leucite-reinforced is greater than lithium disilicate followed by zirconia (Tables 3 and 4, Graphs 1 and 2). As the crystalline content increases, translucency decreases and the polycrystalline ceramics like zirconia appear opaque and are expected to attenuate more light.

The polymerization of dual-cured resin cement depends upon the light-activation element as well as the quantity and efficiency of the chemical component.¹⁷ The self-curing chemical component can play an important role in polymerization, especially in areas that are inaccessible to curing light.¹² The behavior of the cement used in this study seems to depend more on light activation. Therefore, in an effort to try to maximize the DC as much as possible, increased light curing cycle times may be recommended.

The thickness of the ceramics used in the current study was 1.2 mm, designed to be as close as possible to that used clinically. It has been reported that, when the thickness of restorative materials was increased, the DC and final hardness of most dual-cure resin cements were

reduced.²⁷ In addition to the thickness of the restorative material, light transmission properties of the material may result in inadequate polymerization. Light attenuation may affect the polymerization of resin cements used with opaque and even translucent restorative materials.

Although the conversion as demonstrated by the hardness values was good, it still remains that the luting agents tested required 24 hours to reach their maximum cure. Light curing had a marked effect in the initial 10 minutes, but after this period all groups advanced, in terms of hardness, at very similar rates. This is a reflection of the polymerization kinetics being the same whether the free radicals are provided by photo-initiation or chemical reaction.

LIMITATIONS OF THE STUDY

In clinical situations, the microhardness may be affected by water absorption because resin cement is exposed to saliva after cementation. Also, the higher intraoral temperatures may have an influence on the kinetics of chemical reaction. The *in vitro* nature of the study does not replicate the intraoral conditions. Hence, further *in vivo* investigations need to be carried out.

It should also be noted that different brands of dual-cured resin cements have different ratios of light/chemical catalysts; this may result in differences of polymerization efficiency in different commercial brands of dual-cured resin cement.^{11,32,33}

CONCLUSION

Within the limitations of the study, it may be concluded as follows:

- Ceramic composition affected the polymerization of dual-cured resin cements.
- The VHN of the resin cement disks when irradiated through leucite-reinforced ceramic disk was reported to be greater than lithium disilicate disk, followed by zirconia disk, which showed the least values.
- Doubling the light irradiation time significantly increased mean microhardness value. Hence, dual-cured resin cements should always be photo activated for longer periods than recommended by the manufacturers, when intervening ceramic materials attenuate light.
- Greater DC leading to an increase in hardness was observed when the resin cement disks were evaluated after 24 hours.
- Indirect polymerization through ceramic disks showed lower VHN values of dual-cured resin cement as compared to direct activation.

REFERENCES

1. Pollington S, van Noort R. An update of ceramics in dentistry. *Int J Clin Dent* 2;(4).
2. Denry I, Holloway JA. Ceramics for dental applications: a review. *Materials* 2010;3:351-368.
3. Turp V, Sen D, Poyrazoglu E, Tuncelli B, Goller G. Influence of zirconia base and shade difference on polymerization efficiency of dual-cure resin cement. *J Prosthodont* 2011 Jul;20(5):361-365.
4. Davidson CL. Luting cement, the stronghold or the weak link in ceramic restorations? *Adv Eng Mater* 2001;3(10):763-767.
5. Phillips AK. 'Science of dental materials'. 10th ed. Philadelphia: WB Saunder; 1996. p. 85-102.
6. Marquis P. The influence of cements on the mechanical performance of dental ceramics. *Bioceramics* 1992;5(2):317-324.
7. Fleming GJ, Maguire FR, Bhamra G, Burke FM, Marquis PM. The strengthening mechanism of resin cements on porcelain surfaces. *J Dent Res* 2006;85(3):272-276.
8. Rosenstiel SF, Gupta PK, Van der Sluys RA, Zimmerman MH. Strength of a dental glass-ceramic after surface coating. *Dent Mater* 1993;9(4):274-279.
9. Jukka P. Matinlinna 'Adhesion aspects in dentistry'. Leiden, Boston: Brill Academic Pub; 2009. p. 121-138.
10. Hofmann N, Papsthart G, Hugo B, et al. Comparison of photo-activation versus chemical or dual-curing of resin-based luting cements regarding flexural strength, modulus and surface hardness. *J Oral Rehabil* 2001;28(11):1022-1028.
11. Darr AH, Jacobson PH. Conversion of dual cure luting cements. *J Oral Rehabil* 1995;22(1):43-47.
12. El-Badrawy WA, El-Mowafy OM. Chemical versus dual curing of resin inlay cements. *J Prosthet Dent* 1995;73(6): 515-524.
13. Pick B, Gonzaga CC, Junior WS, Kawano Y, Braga RR, Cardoso PE. Influence of curing light attenuation caused by aesthetic indirect restorative materials on resin cement polymerization. *Eur J Dent* 2010 Jul;4(3):314-323.
14. Santos MJ, Passos SP, da Encarnacao MO, Santos GC Jr, Bottino MA. Hardening of a dual-cure resin cement using QTH and LED curing units. *J Appl Oral Sci* 2010 Mar-Apr;18(2):110-115.
15. Rasetto FH, D Riscoll CF, von Fraunhofer JA. Effect of light source and time on the polymerization of resin cement through ceramic veneers. *J Prosthodont* 2001;10(3):133139.
16. Koch A, Kroeger M, Hartung M, Manetsberger I, Hiller KA, Schmalz G, Friedl KH. Influence of ceramic translucency on curing efficacy of different light-curing units. *J Adhes Dent* 2007 Oct;9(5):449-462.
17. Hasegawa EA, Boyer DB, Chan DC. Hardening of dual-cured cements under composite resin inlays. *J Prosthet Dent* 1991 Aug;66(2):187-192.
18. Strydom C. Curing lights-the effects of clinical factors on intensity and polymerization. *SADJ* 2002;57(5):181-186.
19. Asmussen E. Restorative resins: hardness and strength vs. quantity of remaining double bonds. *Scand J Dent Res* 1982;90(6):484-489.
20. Jandt KD, Mills RW, Blackwell GB, Ashworth SH. Depth of cure and compressive strength of dental composites cured with blue light emitting diodes (LEDs). *Dent Mater* 2000;16(1): 41-47.
21. Peutzfeldt A, Asmussen E. The effect of post curing on quantity of remaining double bonds, mechanical properties, and in vitro wear of two resin composites. *J Dent* 2000;28(6): 447-452.
22. Pianelli C, Devaux J, Bebelman S, Leloup G. The micro-Raman spectroscopy, a useful tool to determine the degree of conversion of light-activated composite resins. *J Biomed Mater Res* 1999;48(5):675-681.
23. Shortall AC, Harrington E. Effect of light intensity on polymerization of three composite resins. *Eur J Prosthodont Restor Dent* 1996;4(2):71-76.
24. Hooshmand T, Mahmoodi N, Keshvad A. Microhardness of a resin cement polymerized by light-emitting diode and halogen lights through ceramic. *J Prosthodont* 2009 Jul;18(5): 411-416.
25. Rueggeberg FA, Craig RG. Correlation of parameters used to estimate monomer conversion in a light-cured composite. *J Dent Res A* 1988;67(6):932-937.
26. Rueggeberg FA, Ergle JW, Mettenburg DJ. Polymerization depths of contemporary light-curing units using microhardness. *J Esthet Dent* 2000;12(6):340-349.
27. El-Mowafy OM, Rubo MH. Influence of composite inlay/onlay thickness on hardening of dual-cured resin cements. *J Can Dent Assoc* 2000;66(3):147.
28. Tango RN, Sinhoreti MAC, Correr AB, Correr-Sobrinho L, Consani RLX. Effect of veneering materials and curing methods on resin cement Knoop hardness. *Braz Dent J* 2007;18(3):235-239.
29. Pereira SG, Fulgêncio R, Nunes TG, Toledano M, Osorio R, Carvalho RM. Effect of curing protocol on the polymerization of dual-cured resin cements. *Dent Mater* 2010 Jul;26(7): 710-718.
30. Valentino TA, Borges GA, Borges LH, Vishal J, Martins LR, Correr-Sobrinho L. Dual resin cement knoop hardness after different activation modes through dental ceramics. *Braz Dent J* 2010;21(2):104-110.
31. Meng X, Yoshida K, Atsuta M: Influence of ceramic thickness on mechanical properties and polymer structure of dual-cured resin luting agents. *Dent Mater* 2008;24(5):594-599.
32. Aguiar TR, Di Francescantonio M, Ambrosano GM, et al: Effect of curing mode on bond strength of self-adhesive resin luting cements to dentin. *J Biomed Mater Res B Appl Biomater* 2010;93(1):122-127.
33. Lu H, Mehmood A, Chow A, et al. Influence of polymerization mode on flexural properties of esthetic resin luting agents. *J Prosthet Dent* 2005;94(6):549-554.